

Additional Documentation for the UTA/HOBO

The UTA/HOBO is designed as a precision interface between LI-COR light sensors (Quantum PAR, Pyranometer or Photometer) and the Onset HOBO data logger. LICOR sensors provide a small signal in the range of microamps, whereas the HOBO inputs require a signal in the range of 0–2.5 volts. The UTA/HOBO provides this amplification, and it also has features that allow it to operate directly from the HOBO power supply.



Figure 1:

A UTA serves as a link between a LI-COR sensor and the Onset HOBO data logger. The UTA amplifies the tiny current signal from the LI-COR sensor and outputs a voltage compatible with the HOBO.

The UTA/HOBO is manufactured in two models. The base model (“UTA/HOBO”) is for use with a SZ model LI-COR sensor, while the “UTA/HOBO/BNC” is for use with the SA model LI-COR sensors which have BNC connectors on their input cables. It should be noted that BNC connectors are not waterproof, and should be used only in areas that are sheltered from water exposure. For best water resistance, use the SZ model LI-COR sensors

The UTA/HOBO connects to the HOBO via a voltage input cable available from Onset (their part number “CABLE-2.5-STEREO”). The mini stereo plug connects to one of the input ports on the side of the HOBO data logger. The other end of the cable end has three bare wires and goes through the gland nut on the side of the UTA nearest the three-position terminal on the UTA circuit board. The wires are then be screwed down under the terminals according to color code (Figure 2, next page). The LI-COR sensor attaches to the UTA through the gland nut closest to the two-position terminal for SZ model LI-COR sensors (figure 2), or by simply connecting to the BNC connector for the SA model sensors.

The HOBO power supply is a small 3V lithium battery, but despite its small size, it is capable of operation for long periods of time between battery changes. Most of the time, the HOBO is in a sleep mode wherein it requires little power. At a specific time interval (which you determine when you launch the HOBO), the data logger wakes up, turns on the external power supply (red wire on the stereo cable), and records the data coming in from the sensors. There is a 2 millisecond pause between the wake up and the first measurement. After taking up to four measurements in quick succession, the power supply turns off and the HOBO goes back to sleep. The UTA is powered from the 2.5 volts provided by the HOBO on the red wire in the cable. The UTA draws about the same current (125 μ amps) as the Onset thermistor temperature probe, so the UTA does not compromise the HOBO battery life. In the UTA/HOBO, some components of the base model UTA have been replaced in order to meet the special low voltage, low current, and high speed, requirements of the HOBO.

Figure 2
Connections.

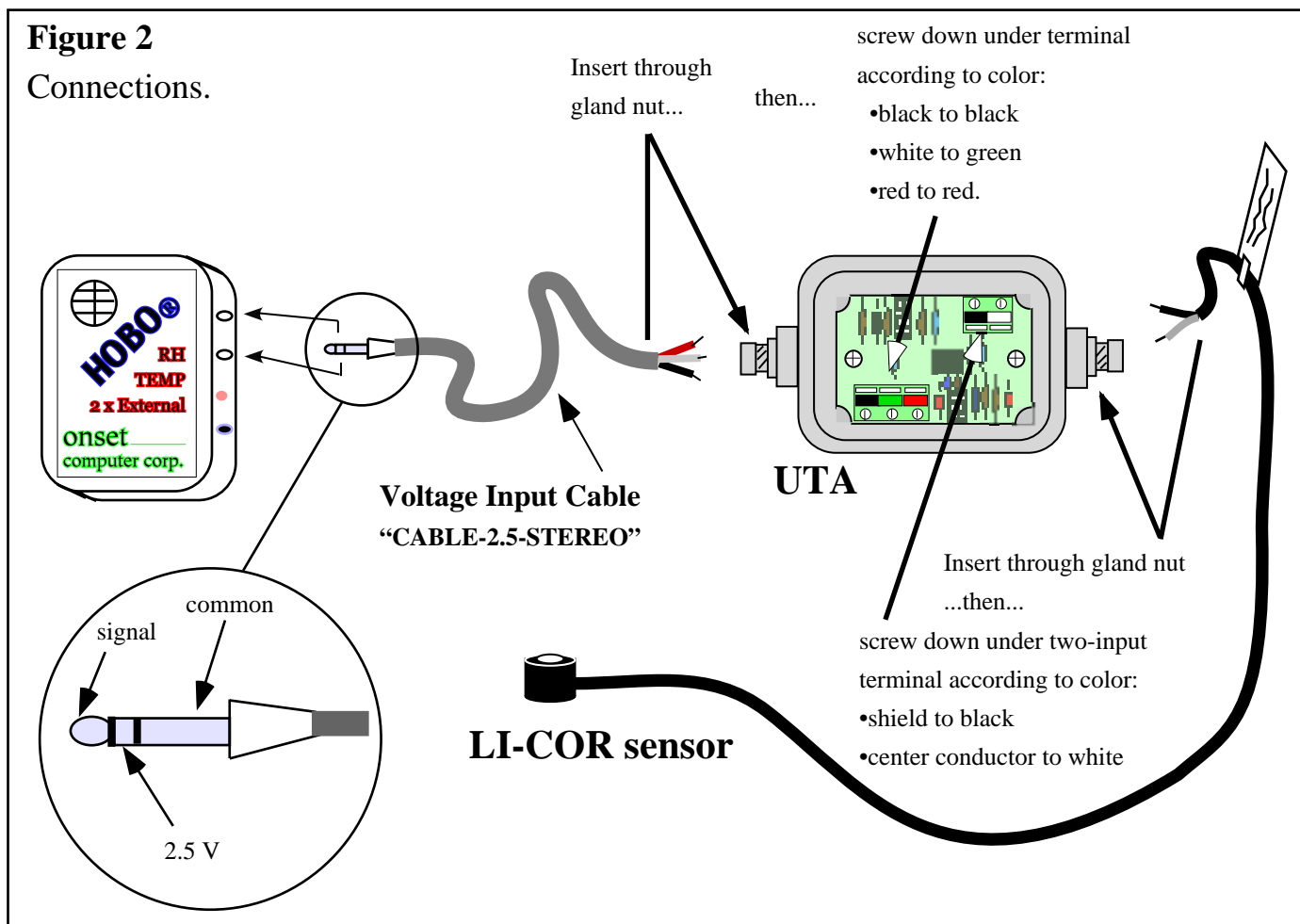

Calculations:

The external channels on the Onset HOBO data loggers record voltage. When you acquire readings from the logger, using the Boxcar software, those readings will be in volts. You will want to convert Volts to units of light measurement. Drop the negative sign from the LI-COR sensor multiplier.

LI190 Quantum PAR sensor example:

- UTA/HOBO gain = 6.4 microamps per Volt (2.5 Volts full scale output at 16 μ amps input)
- multiplier, from LI190 calibration tag or certificate (for example) = 145 μ moles/m²s per μ amp
- Volts reading from HOBO = 1.25 (for example)

$$\Rightarrow \text{light level} = [(\text{HOBO Volts}) * 6.4] * \text{multiplier} = (1.25 * 6.4) * 145 = \mathbf{1160 \mu\text{moles/m}^2\text{s}}$$

LI200 Pyranometer sensor example:

- UTA/HOBO gain = 48 microamps per Volt (2.5 volts full scale output at 120 μ amps input)
- multiplier, from LI200 calibration tag or certificate (for example) = 11.5 watts/m² per μ amp
- volts reading from HOBO = 1.25 (for example)

$$\Rightarrow \text{light level} = [(\text{HOBO volts}) * 48] * \text{multiplier} = (1.25 * 48) * 11.5 = \mathbf{690 \text{ watts/m}^2}$$

LI210 Photometer sensor example:

- UTA/HOBO gain = 19.2 volts per microamp (2.5 volts full scale output at 48 μ amps input)
- multiplier, from LI210 calibration tag or certificate (for example) = 2.88 K lux per μ amp
- volts reading from HOBO=1.25 (for example)

$$\Rightarrow \text{light level} = [(\text{volts from HOBO} * 19.2)] * \text{multiplier} = (1.25 * 19.2) * 2.88 = \mathbf{69.12 \text{ K lux}}$$