

Strip wires back 3/8" and tin. Bend wires up 0.240" out from the insulation.

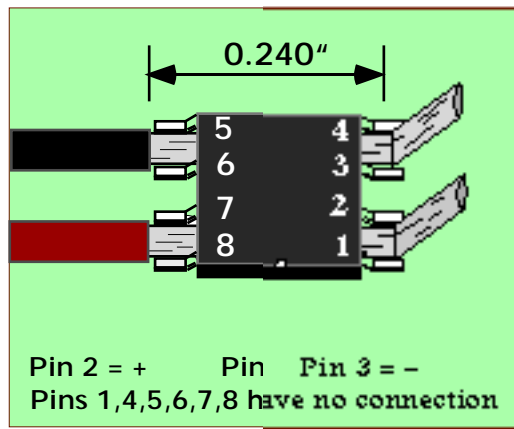

Only 2 pins on the 8-pin package are connected.

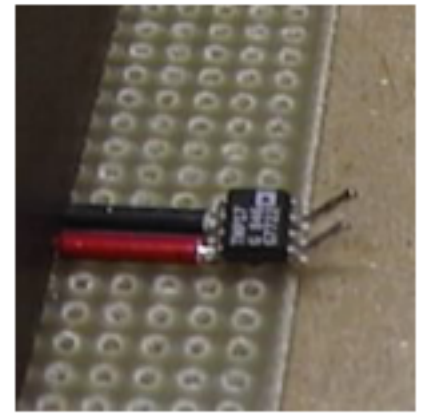

Set the chip on top of the bent wires.



Clamp the chip, trim the wires. Or you could trim the wires before placing the chip.



Solder pins 1 and 2 to the red (+) wire, and solder pins 3 and 4 to the black (-) wire.

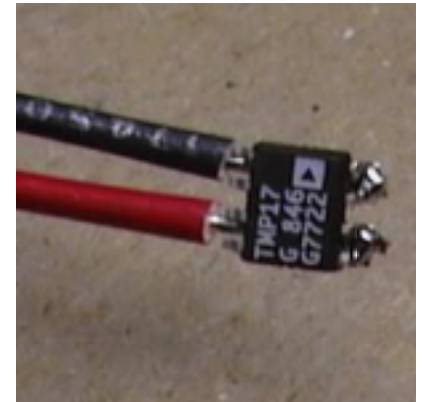

After soldering

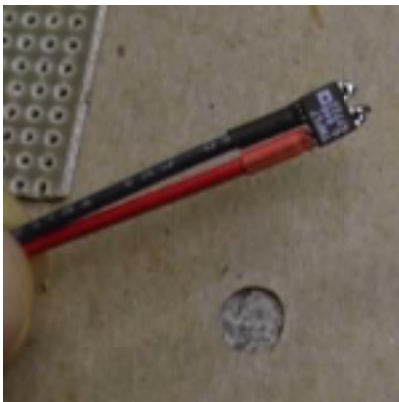

Shrink tubing over individual wires is optional. Shrink tubing can hook over pins 5,6 and 7,8 for added mechanical strength.



Insulate the assembly with adhesive lined heat shrink tubing. The length of tubing can be shorter than shown above.

Right, construction using cable with outer jacket, Belden 8442.

